

Plan Below Roof Slab

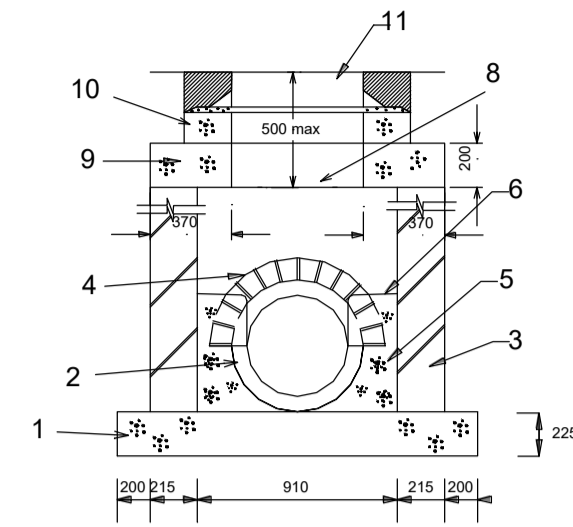

Section A-A

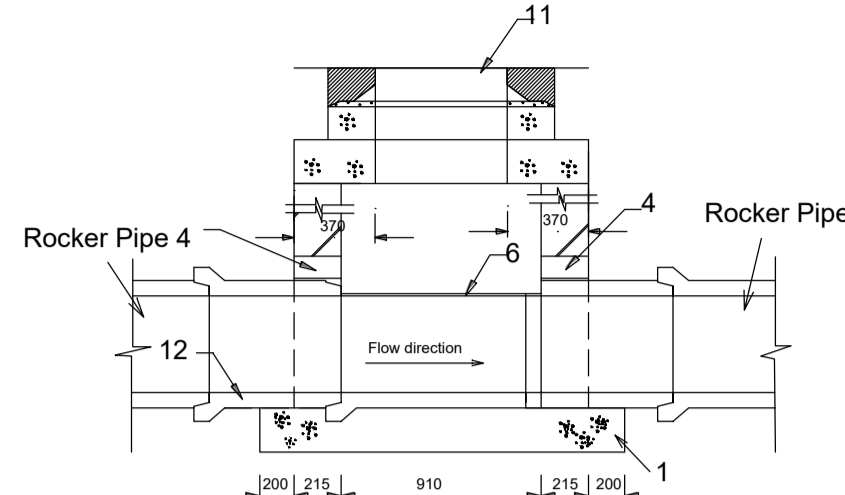

Section B-B

Manhole Details For Pipe Diam's. 150, 225, 300, 375, 450.
Depth to Invert Less than 1.0m.

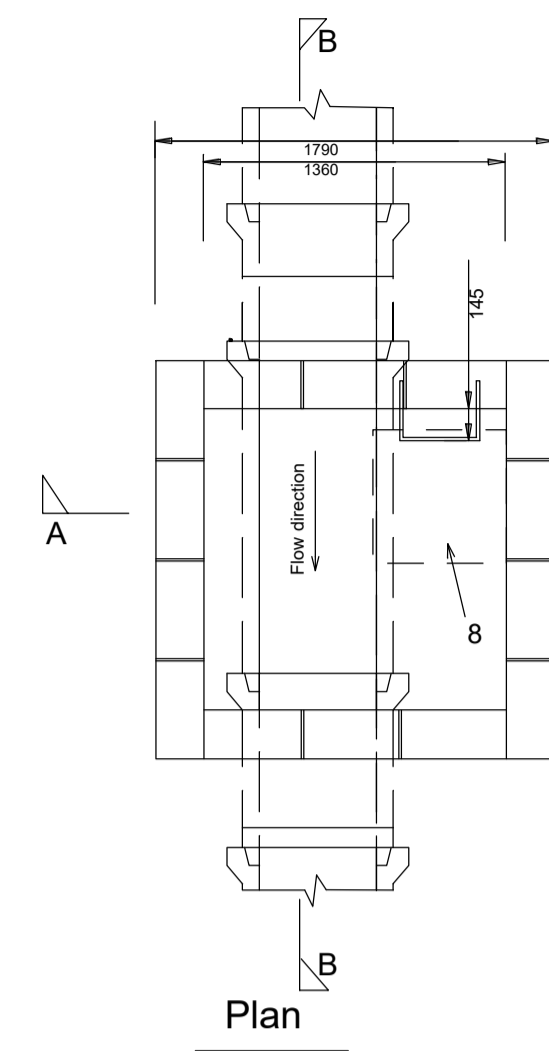

Plan

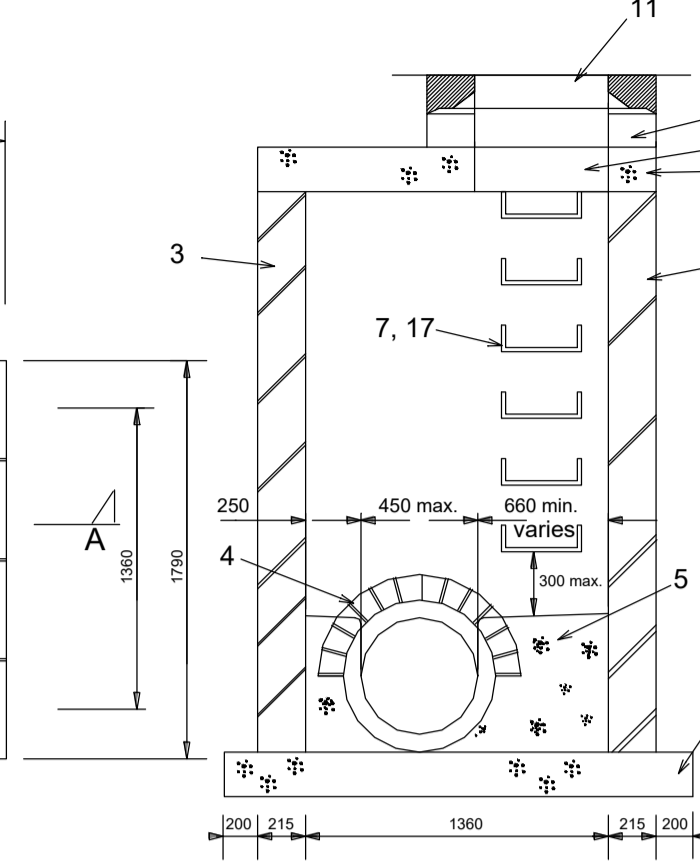

Section A-A

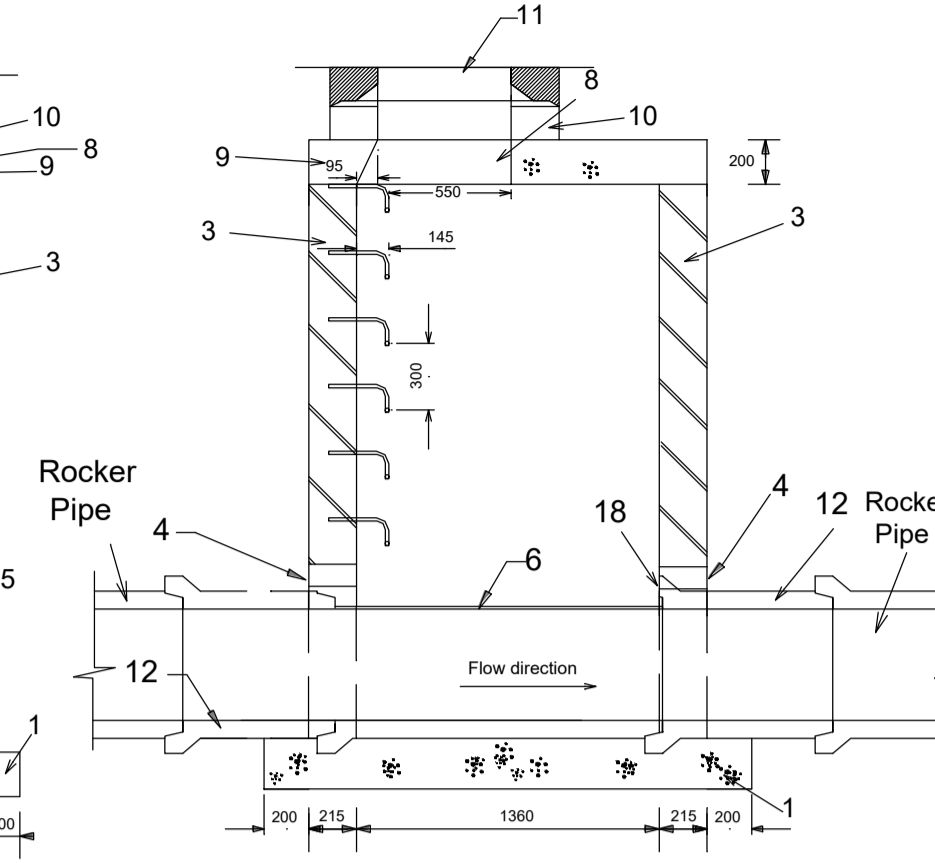

Section B-B

Manhole Details For Pipe Diam's. 225, 300, 375, 450.
Depth to Invert 1m to 3m.

TYPE A MANHOLE.

NTS

TYPE B MANHOLE.

NTS

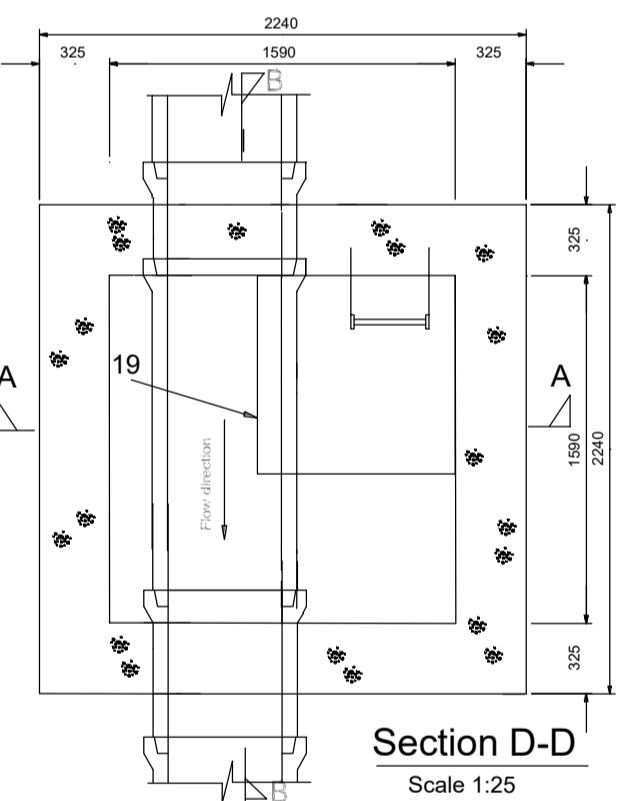

Section D-D
Scale 1:25

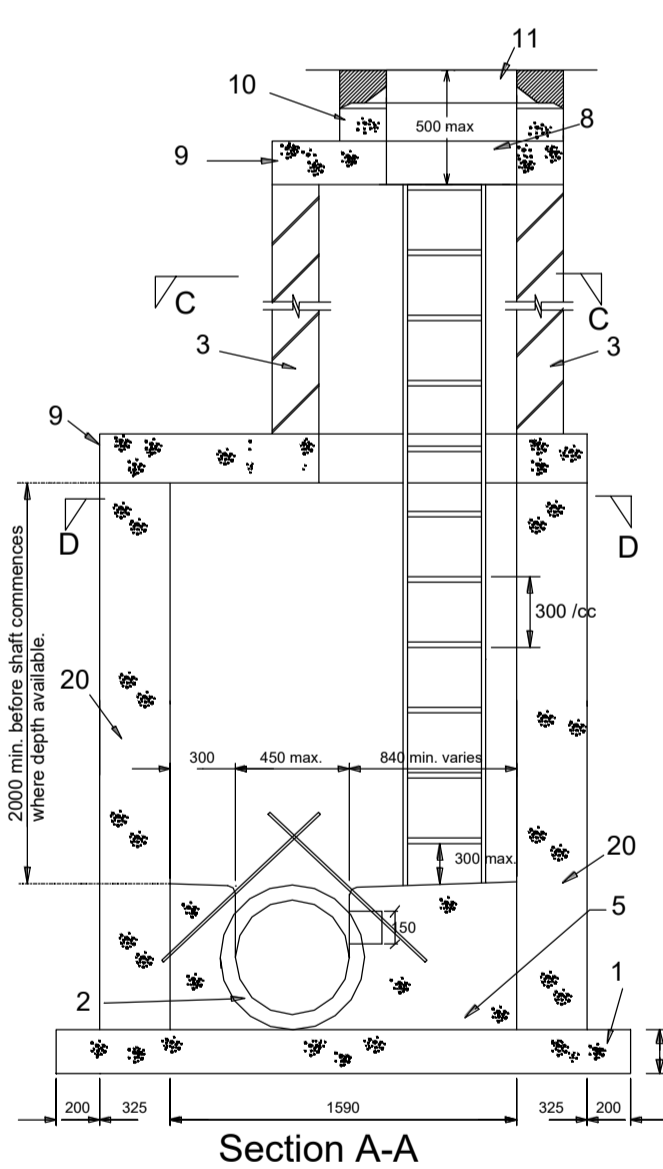

Section A-A

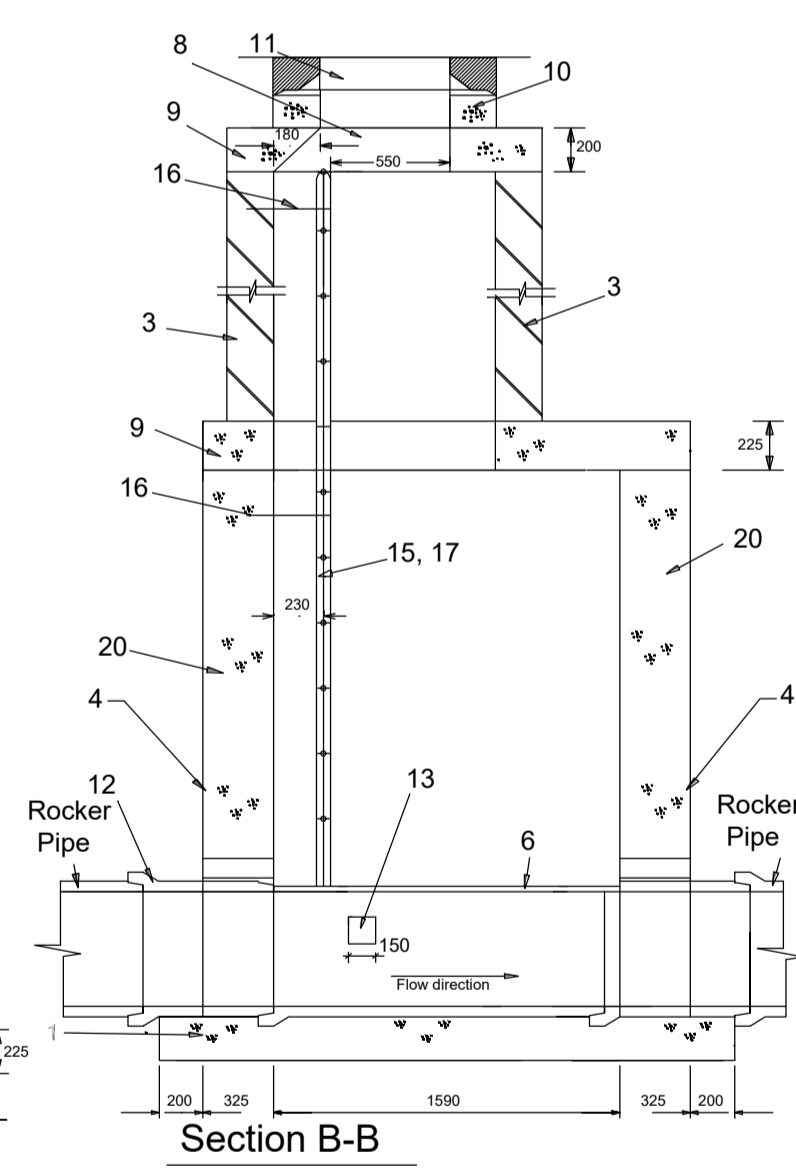

Section B-B

Manhole Details For Pipe Diam's. 225, 300, 375, 450.
Depth to Invert 3m. to 6m.

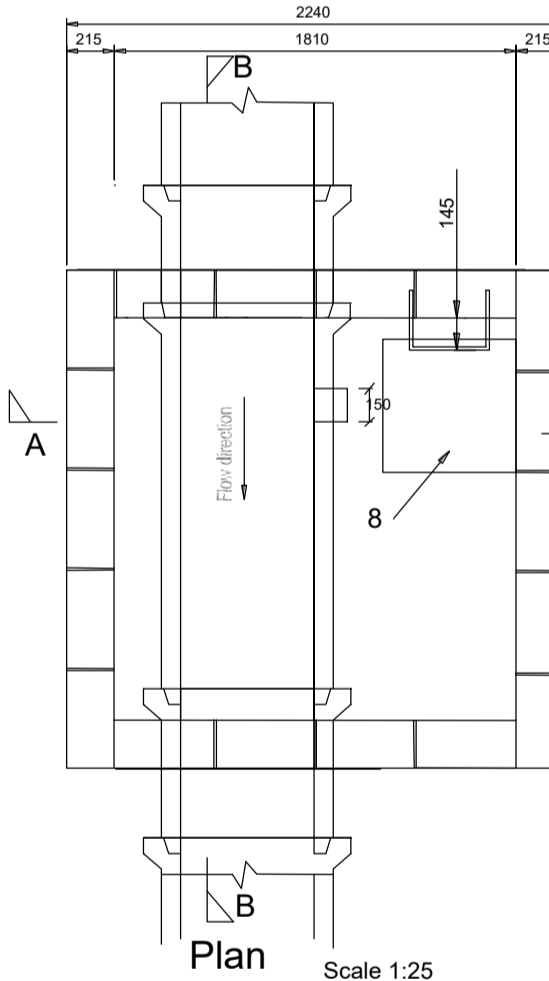

Plan

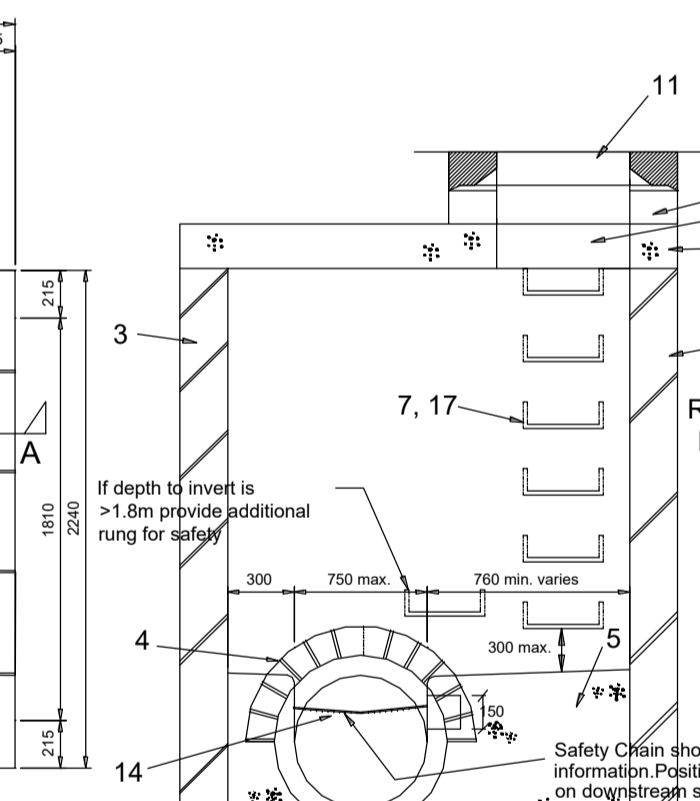

Section A-A

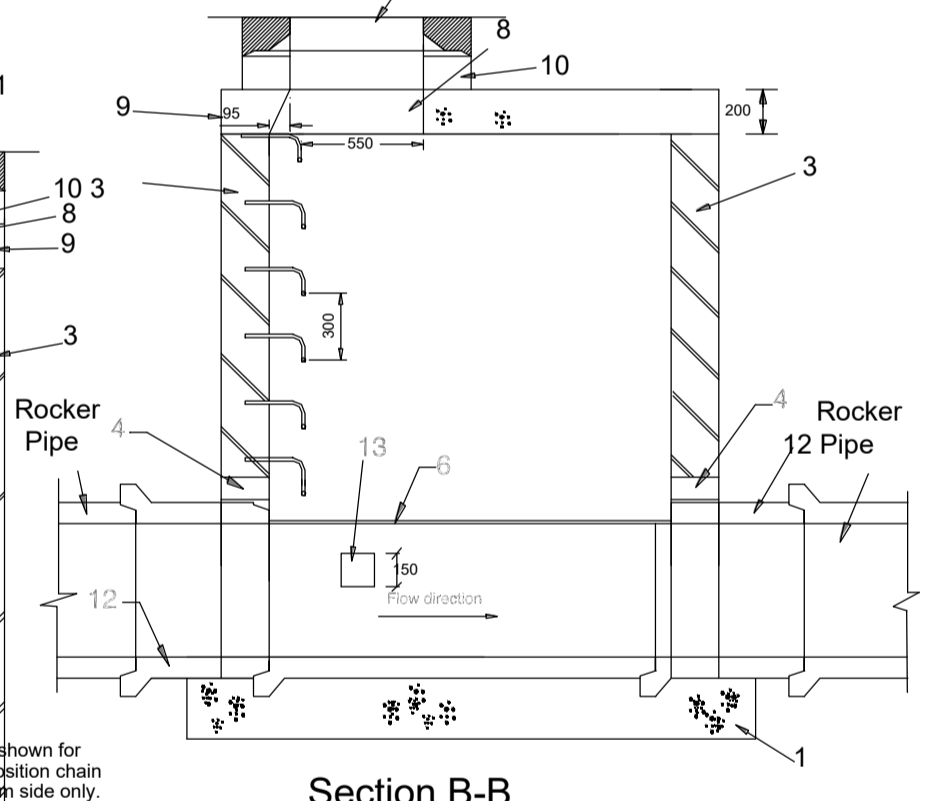

Section B-B

Manhole Details For Pipe Diam's. 525, 600, 675 & 750mm
Depth to Invert 1.0m to 3m.

TYPE C MANHOLE.

NTS

TYPE D MANHOLE.

NTS

Drawing Notes:

- 225mm thick Cl. 20N/20mm Mass Concrete Foundations.
- Preformed half circle channel pipes. The pipeline may, where practicable, be laid through the manhole and the crown cut out to half diameter, provided flexible joints are situated on each side no further than 600mm from the inner face of manhole wall.
- Manhole construction.
For Surface Water Manholes high-density blocks to Cl.S10 of IS.20 Part 1:1987 or Cl. 30N/20mm insitu concrete.
Block work shall be bedded and jointed using mortar to IS406. Beds and vertical joints shall be completely filled with mortar as the blocks are laid.
Joints shall be flush pointed as the work proceeds.
All Foul Manholes must be faced in solid Engineering Brick (min. class A or B), or insitu concrete for 1 metre above Benching Level. Brick to be bonded to block work using English Garden Wall Bond.
- Relieving arch formed by 215x103x65 solid engineering brick Class A or B as per drawing.
Relieving arches used in brick or block work manholes extend over full thickness of wall.
A Double Arch is to be formed for pipe diameters greater than 600mm.
- Benching and pipe channel pipe surround Cl. 20/20 concrete.
- Benching finished in 2:1 sand-cement mortar with a smooth trowel finish, at 1 in 30 slope towards channel.
- Standard rungs at 300c/c vertically and galvanized to the latest version of B.S. 729 or equivalent. Note: Steps Irons are not acceptable.
- 600mm square ope in roof slab.
- Precast R.C. Roof Slab shall be 200mm thick in Class 30N/20mm, with 40mm cover to steel.
- 1 to 2 courses of solid engineering bricks Cl.B to I.S.91:1983 set in 1:3 (cement and mortar).
- Class D400 or E600 manhole cover and frame to IS/EN 124, 150mm deep frame for roads and 100mm deep for footpaths and green areas. Non-rock design, closed keyways, manufactured from spheroidal graphite cast iron (ductile cast iron), 600 x 600 (600diam.) clear opening, cover and frame coated in bitumen or other approved material, cover to have a minimum mass of 140kg/m², frame bearing area shall be 80,000mm² min, frames shall be designed to prevent covers falling into manhole. Frames shall be bedded on approved mortar to manufactures instructions.
- Short length pipe and pipe joint external to manhole shall not exceed 600mm from the inner face of manhole wall.
- Toe holes of 230mm minimum depth and galvanized steel safety railings to be provided in benching of sewers greater than 525mm diameter and depth to invert >3m for access to invert.
- A safety chain is to be provided on pipes that exceed 450mm in diameter. Mild safety chain shall be 10mm nominal size grade M(H) non-calibrated chain, type 1, complying with B.S.4942 Part 2 or equivalent.
- When depth of manholes to invert is greater than 3.0m ladders shall be used instead of rungs to B.S.4211 or equivalent except that stringers should be not less than 65 x 12mm in section and rungs 25mm in diameter. Fixed ladders should meet the dimensional requirements of B.S.4211 or equivalent.
- Ladder stringers should be adequately supported from the manhole wall at intervals of not more than 2.0m stringers should be bolted to cleats to facilitate renewal.
- All ladders, rungs, handrails, safety chains etc shall be hot dip galvanized to B.S.729 or equivalent.
- Pipe should be cut flush with the inside surface of the manhole wall so that the channel extends the full length of the manhole (except for pre-cast manholes).
- Position of 910 square ope in intermediate roof slab.
All manholes shall be watertight to the satisfaction of the Engineer. Formwork to Reinforced Concrete and Mass Concrete shall comply with Class 2, Section 6.2.7, B.S.8110: Part 1: 1997. Finish to the top of slabs shall comply with Type A, Section 6.2.7.3, B.S.8110: Part 1:1997.
Plan dimensions of manholes are based on block work having a co-ordinating size of 450 x 225 x 100.
Manholes are designed to B.S.8005 and wall thickness to L.S.325 block work design code taking granular fill pressure and H.B. surcharge. Reinforcement to slabs to Engineers details.
- For manholes >3m depth to invert use 30N/20mm insitu concrete. Reinforcing mesh ref. A393 @ 6.16kg/m to be fixed at mid point of wall. Additional reinforcement to be supplied over pipe crown.
- Manhole Openings to be situated furthest from the nearest Carriageway. Manhole steps / access to be positioned to allow viewing of oncoming traffic.
- Surface Water Infrastructure to be in accordance with the Greater Dublin Regional Code of Practice for Drainage Works.

General Notes:

- All brick to be Solid Engineering Brick Class A or B.
- For pipe diameter >750mm use manhole with internal diameter size = pipe size + 1metre + 300mm.
- Distance from the top rung of the ladder to ground level must be a maximum of 500mm.

PLANNING DRAWING.

NOT FOR CONSTRUCTION.
ALL LEVELS GIVEN ARE
RELATIVE TO ORDNANCE DATUM.
THIS DRAWING HAS BEEN ISSUED FOR INFORMATION
PURPOSES ONLY AND MUST NOT BE USED
FOR CONSTRUCTION UNDER ANY CIRCUMSTANCES

NOTES

- For setting out refer to Architect's drawings.
- This drawing to be read in conjunction with all other Architectural and Engineering drawings and all other relevant drawings and Specifications.
- DO NOT SCALE THIS DRAWING. Use figured dimensions only.
- No part of this document may be reproduced or transmitted in any form or stored in any retrieval system of any nature without the written permission as copyright holder except as agreed for use on the project for which the document was originally issued.
- Ordnance Survey Ireland Licence Number EN 0074024

Rev. No.	Date	REVISION NOTE	Dim. By	Chkd. By
P1	16.05.2024	ISSUED FOR STAGE 2 PLANNING	JF	GL
P2	28.06.2024	ISSUED FOR STAGE 3 PLANNING	JS	JF
P3	23.07.2024	ISSUED FOR REVIEW	JS	JF
P4	08.08.2024	ISSUED FOR REVIEW	JF	GF
P5	13.08.2024	ISSUED FOR PLANNING SUBMISSION	JS	GF

Client	LDA
Project	Clongriffin Blocks 5 & 6
Title	Storm Water Drainage Details Sheet 1 of 3
Dwg. No.	CLN-CSC-XX-XX-DR-C-0129
Date	MAY 2024
Dim by	JS
Chkd by	JF
Apprd by	NB
Scale	AS SHOWN @ A1
Revision	P5

CS Consulting Group
DUBLIN | LONDON | LIMERICK

Head Office
19-22 Dame Street, Dublin 2.
T: +353 (0)1 5480863
e: info@csconsulting.ie
w: www.csconsulting.ie

Quality Environment
NSAI Energy
Certified Health & Safety

ISO 9001:2008
ISO 14001:2004
ISO 50001:2011
OHSAS 18001:2007